



HEATH & SHERWOOD

linear sampler

Model 1330-4300 Extra Heavy Duty

Sampling of High Flows for On-stream Analysis and Metallurgical Accounting

All HS Samplers Meet or Exceed Industry's Best Standards

Increase profits from important process streams with accurate sampling. Standard and custom designs available for most pipe sizes and launders.

Typical applications: final tailings, flotation feed, fine ore conveyor, apron feeding discharge, final product discharge.

Easy to Install

- low profile carriage and frame, adapts easily above pump box or head chute
- optional Integrated Cutter Enclosure (ICE[®]) for any application

Continuous Electric Drive System

- ensures uniform cutter velocity through the material stream
- non-reversing motors last longer
- intermittent and continuous operation

Inspection Doors (2)

- removable
- full access for inspection and maintenance
- provides protection from dust and moisture

Vapor Seal

- minimizes vapor and dust from entering drive area through underside of sampler

Cutters and Cutter Caps

- designed to suit each application
- ensures correct increment delimitation and extraction
- construction materials:
 - carbon or abrasion resistant steel
 - molded polyurethane
 - stainless steel
 - others on request

Sample Exit

Artist's Concept

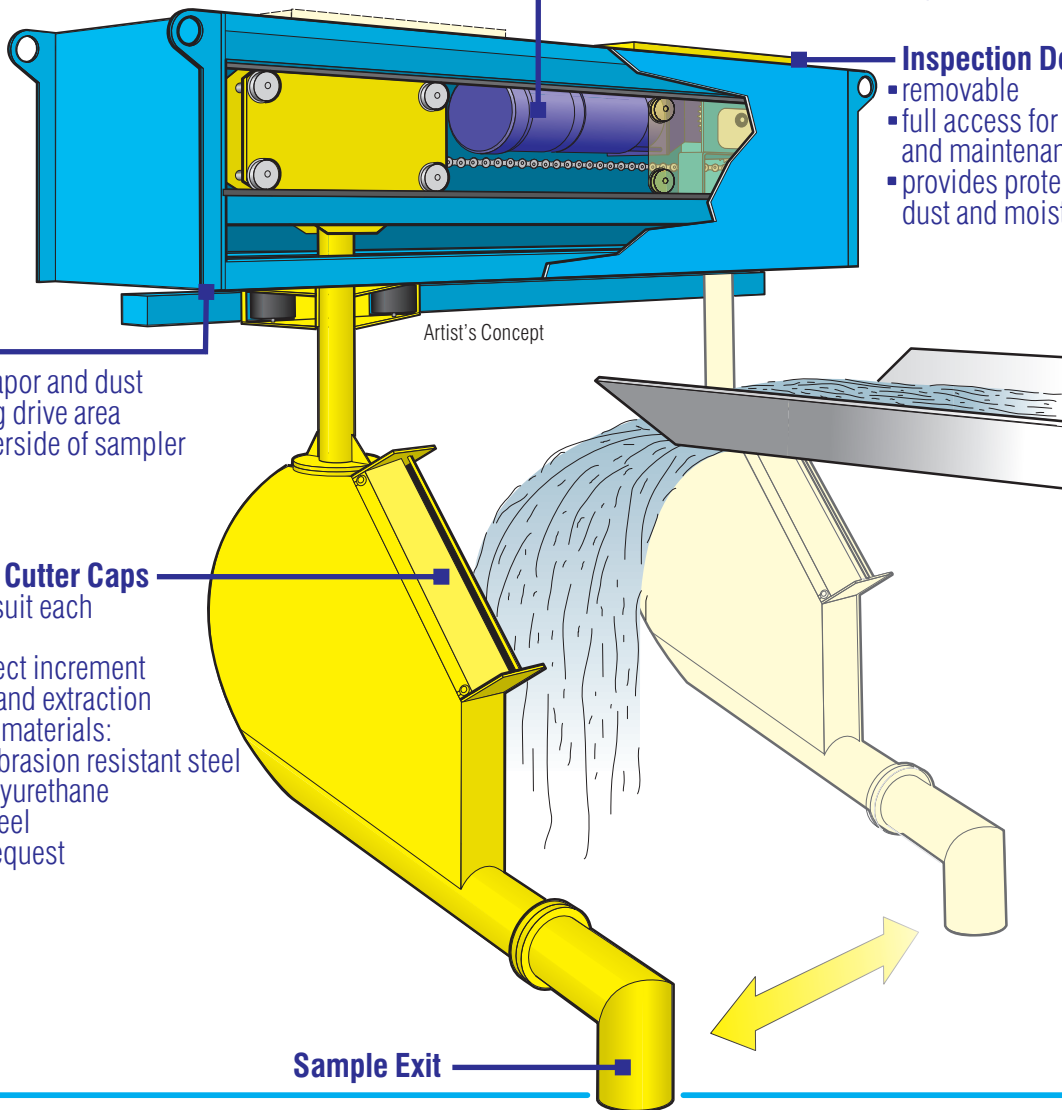

linear sampler

Model M1330 Extra Heavy Duty



major components

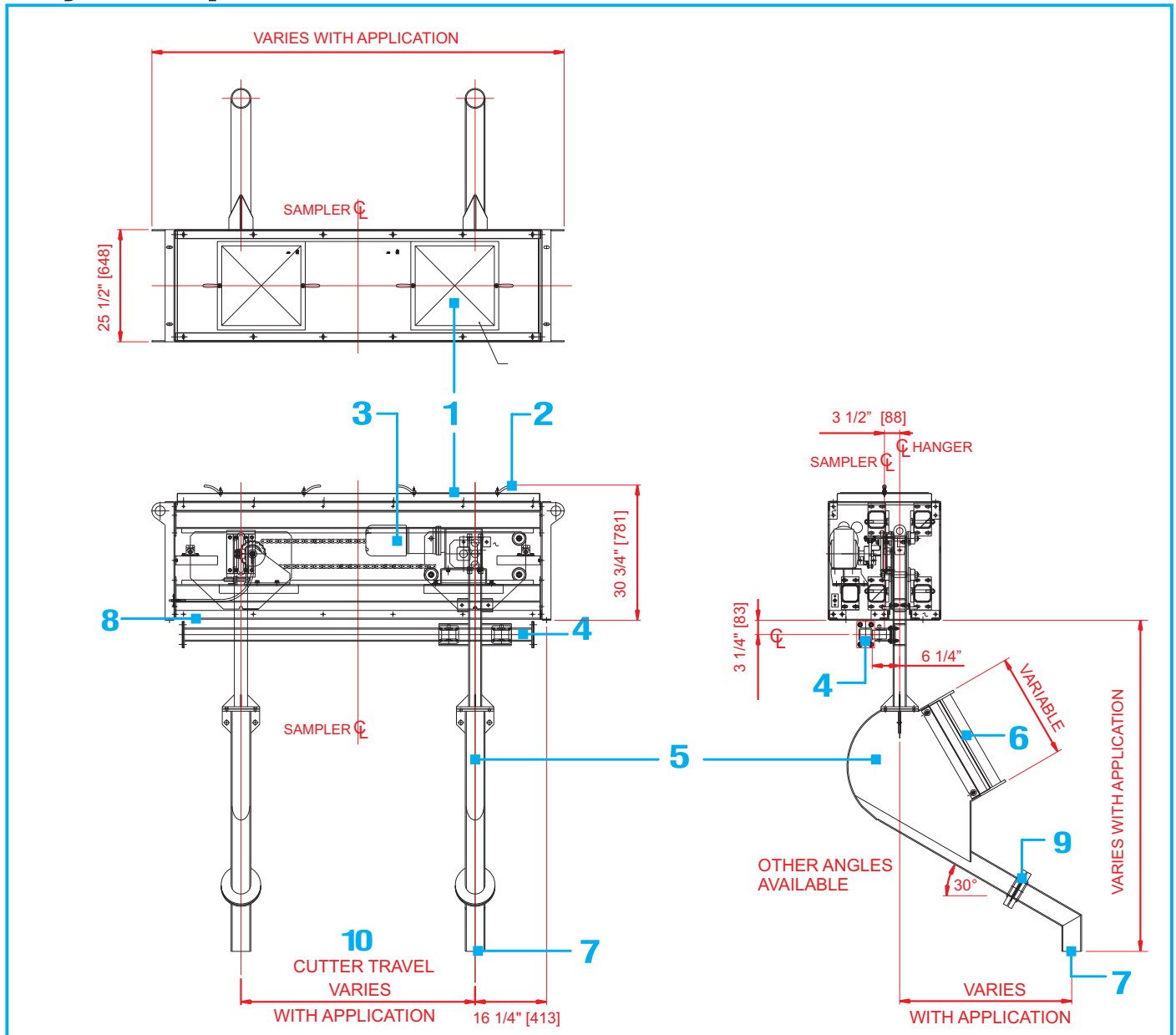

- | | | |
|--|---|---|
| <p>1 removable inspection doors for easy access</p> <p>2 quick-release door latches</p> <p>3 continuous drive motor
-standard motor 1.5 hp (1.1 kW)
-standard electrical rating 575V/3Ø/60Hz (others available)</p> | <p>4 thrust rail</p> <p>5 pelican style type "D" cutter</p> <p>6 fully replaceable cutter cap</p> <p>7 sample exit (4" diameter shown, or depending on application)</p> | <p>8 vapour seal for drive protection</p> <p>9 drip rings</p> <p>10 cutter travel from 36-144" (915-3658 mm) at various speeds and intervals to suit application</p> |
|--|---|---|

Heath & Sherwood (1964) Limited
Box 340 Kirkland Lake, Ontario
Canada P2N 3J2

Tel. (705) 567-5313
Fax. (705) 568-8545
Toll Free in North America:
1 888-go sample (467-2675)
email: info@heathandsherwood64.com

Subsidiary Offices:
Toronto, Ontario Canada
Agents World Wide

Visit our website at:
www.heathandsherwood64.com